

## WKp



### CONSTRUCTION

The fans are made of galvanized steel sheet, the collars, ensuring integration with particular parts of the assembly of the same size, are made of P-20 profile.

Cylinder rotor with a motor with rotating outer axis, protection grade IP 54.

### CAPACITY REGULATION

Electronic or transformer fan regulation.

### HOUSING

Fan housing is possible in any position but the space for motor service must be provided.

### CONNECTION

Connection of the fan with a junction box located on the housing.

### NOISE LEVEL

The tables next to the profile show value of acoustic power at Lws inlet and Lwt outlet of the fan and Lwo sound emission into surrounding in a distance of 1 m.

### DESIGNATIONS

Ducted fan	WKp - 1 - T - 1470
Fan type	1; 2; 3; 4; 5; 6; 7; 8
Motor type	T - three-phase motor J - single phase motor
Revolutions	

## TECHNICAL DATA

### Basic dimensions

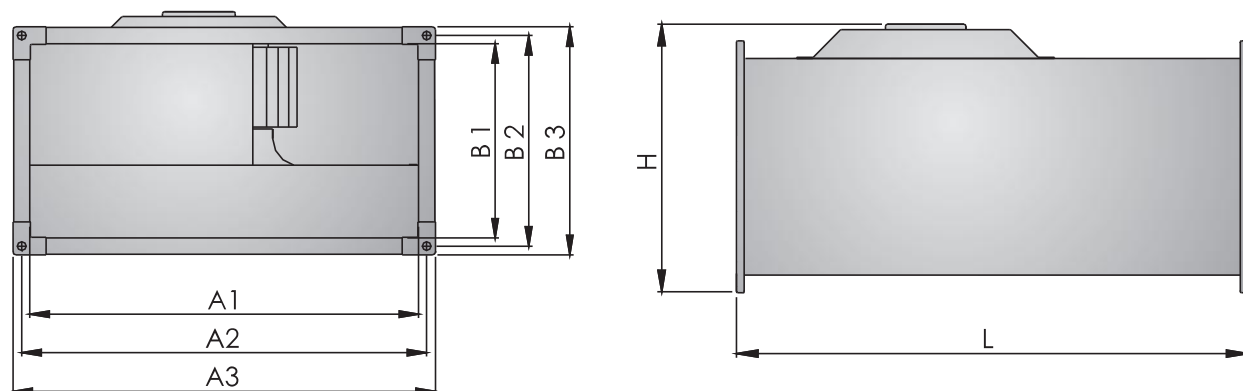

Fan size	A1 [mm]	A2 [mm]	A3 [mm]	B1 [mm]	B2 [mm]	B3 [mm]	H [mm]	L [mm]
Wkp-1	400	416	434	200	216	234	250	470
Wkp-2	500	515	534	250	266	284	310	530
Wkp-3	500	516	534	300	316	334	360	530
Wkp-4	600	616	634	300	316	334	360	530
Wkp-5	600	616	634	350	366	384	420	650
Wkp-6	700	716	734	400	416	434	465	700
Wkp-7	800	816	834	500	516	534	565	800
Wkp-8	900	916	934	500	516	534	570	900

### Motor parameters (three phase motors)

Fan type	Air capacity [m³/h]	Revolutions [rpm]	Motor power [kW]	Voltage [V]	Current [A]	Working temperature [°C]	Operating noise level [dB(A)]			Weight [kg]
							Lws	Lwt	Lwo	
<b>4-poles motors</b>										
Wkp-1	1470	1230	0,31	400	0,51	70	70	73	60	7
Wkp-2	1900	1270	0,56	400	0,95	40	72	77	63	11
Wkp-3	2600	1380	0,93	400	1,9	50	76	80	64	13
Wkp-4	3200	1310	1,5	400	2,6	40	79	82	66	19
Wkp-5	4250	1300	2,5	400	4,1	40	80	85	67	21
Wkp-6	6000	1320	3,7	400	6,0	40	82	88	73	27
Wkp-7	6500	1330	5,1	400	8,1	40	83	89	74	33
<b>6-poles motors</b>										
Wkp-5	3600	750	0,9	400	1,8	40	68	72	60	13
Wkp-6	4000	790	1,1	400	2,0	40	70	74	61	20
Wkp-7	7000	830	2,7	400	4,9	50	76	81	70	29
<b>8-poles motors</b>										
Wkp-8	7100	600	1,85	400	3,8	40	78	82	68	45

### Motor parameters (single phase motors)

Fan type	Air capacity [m³/h]	Revolutions [rpm]	Motor power [kW]	Voltage [V]	Current [A]	Working temperature [°C]	Operating noise level [dB(A)]			Weight [kg]
							Lws	Lwt	Lwo	
Wkp-1	1200	1180	0,36	230	1,8	40	70	74	63	7
Wkp-2	1500	1230	0,51	230	2,3	40	72	76	61	11
Wkp-3	2250	1230	0,78	230	3,4	50	76	80	64	13
Wkp-4	2750	1210	1,15	230	5,1	40	79	81	68	19

## AUTOMATICS

Description of operation and fans automatics components selection are presented in the section: VENTILATORS CONTROL AND AUTOMATICS in this catalogue

## Motor

3~400 V  
0,31 kW  
0,51 A  
1230 rpm

### WKp-1-T-1230

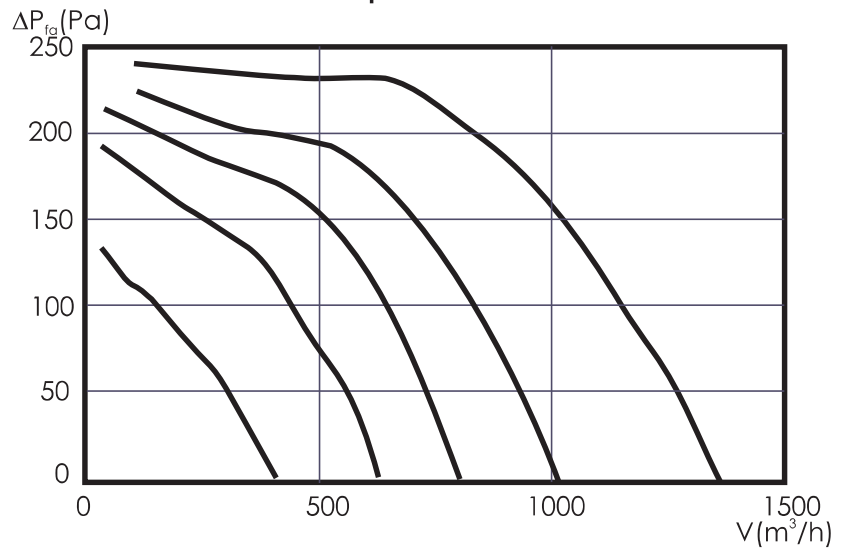

## Motor

1~230 V  
0,36 kW  
1,8 A  
1180 rpm

### WKp-1-J-1180

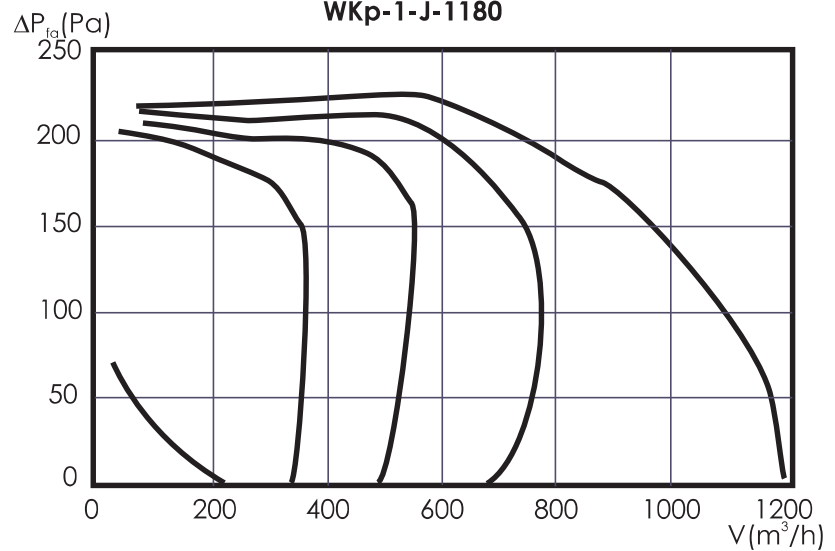

## Motor

3~400 V  
0,56 kW  
0,95 A  
1230 rpm

### WKp-2-T-1270

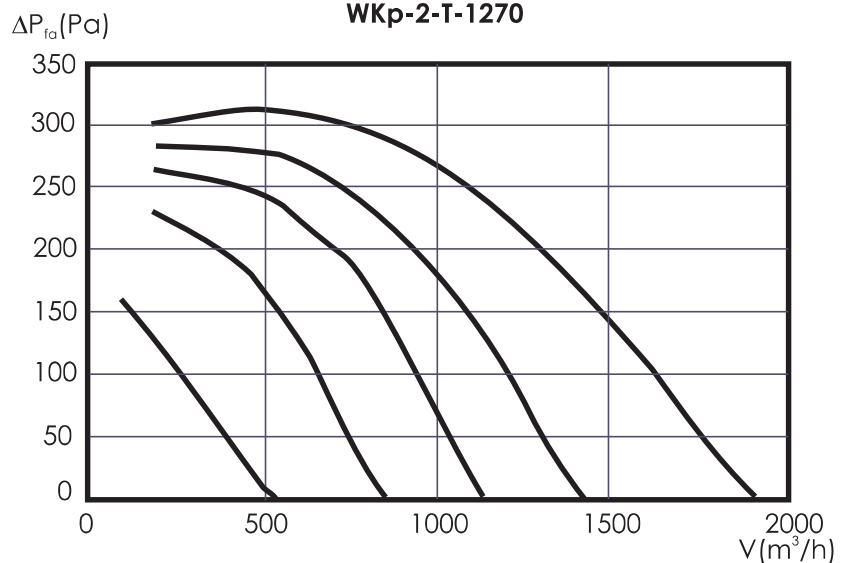

## Motor

1~230 V  
0,51 kW  
2,3 A  
1230 rpm

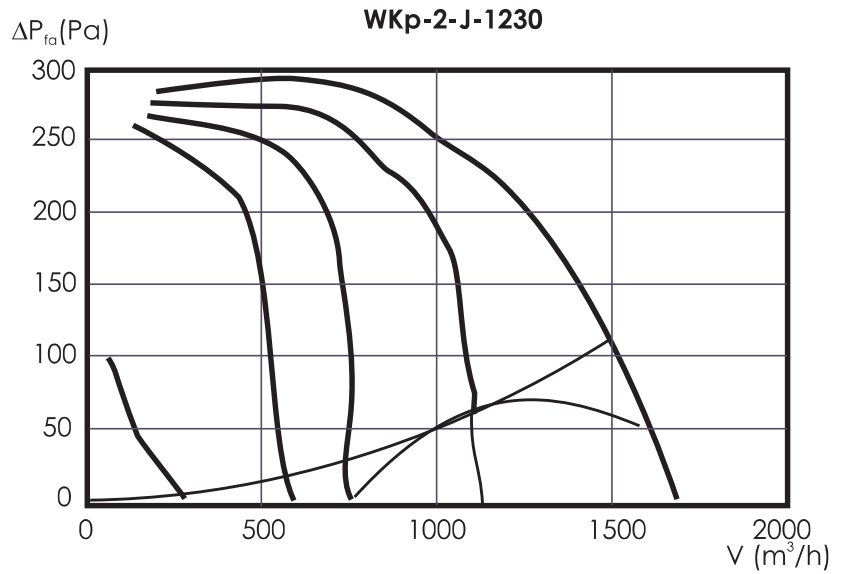

## Motor

3~400 V  
0,93 kW  
1,9 A  
1380 rpm

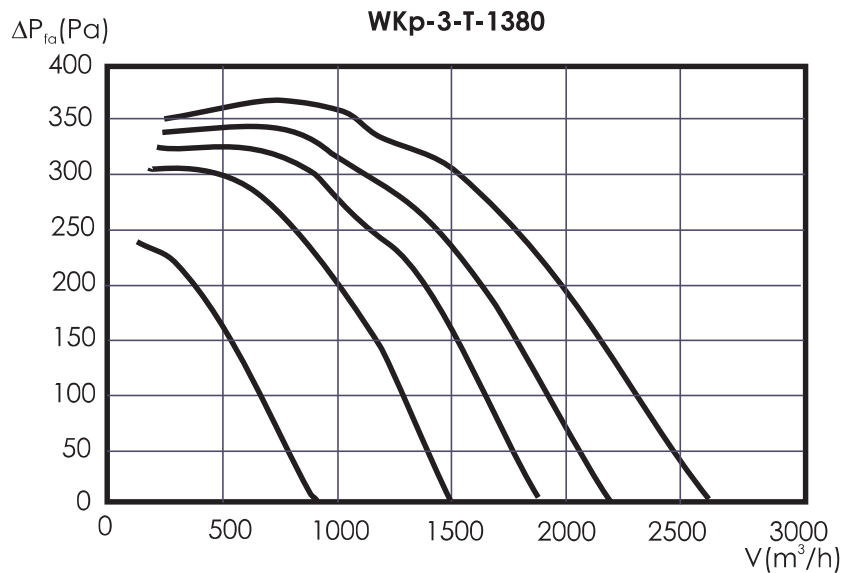

## Motor

1~230 V  
0,78 kW  
3,4 A  
1230 rpm

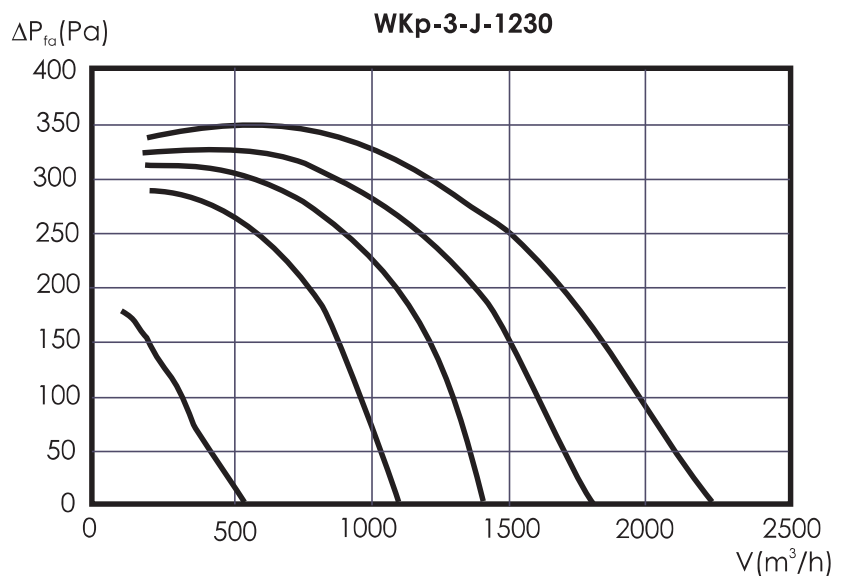

## Motor

3~400 V  
1,5 kW  
2,6 A  
1310 rpm

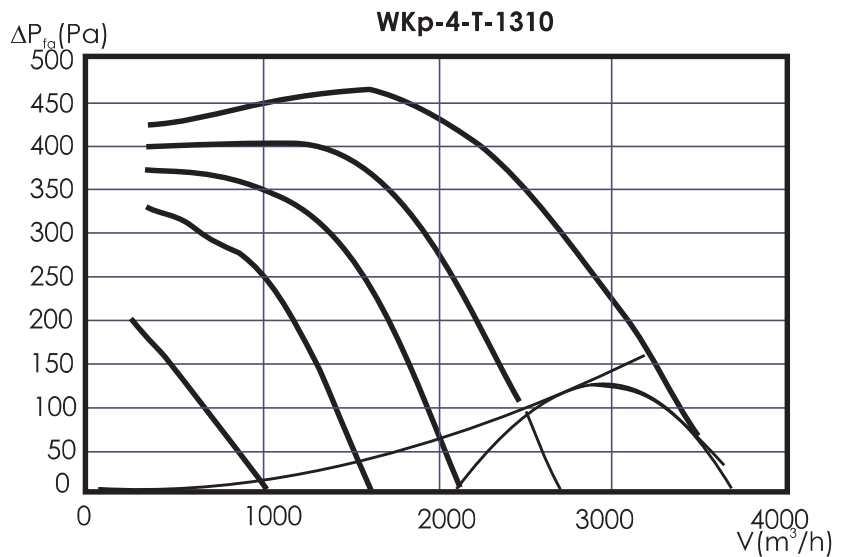

## Motor

1~230 V  
1,15 kW  
5,1 A  
1210 rpm

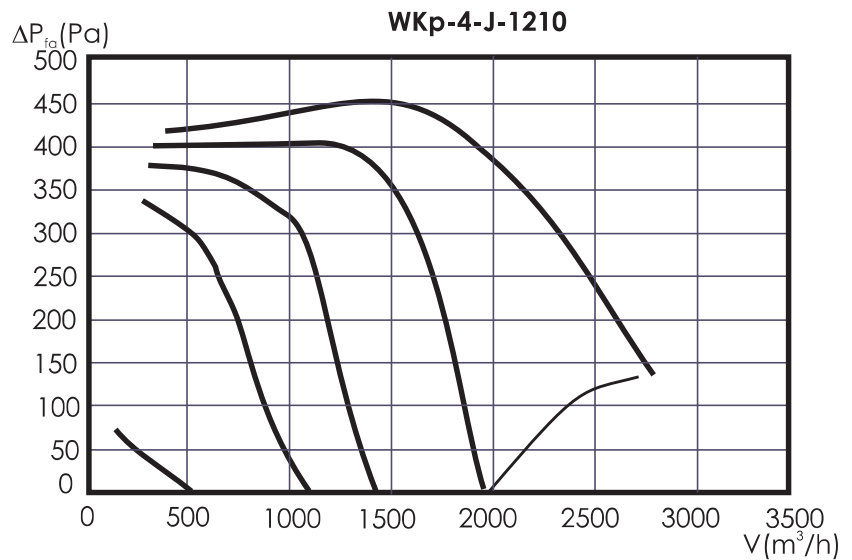

## Motor

3~400 V  
2,5 kW  
4,1 A  
1300 rpm

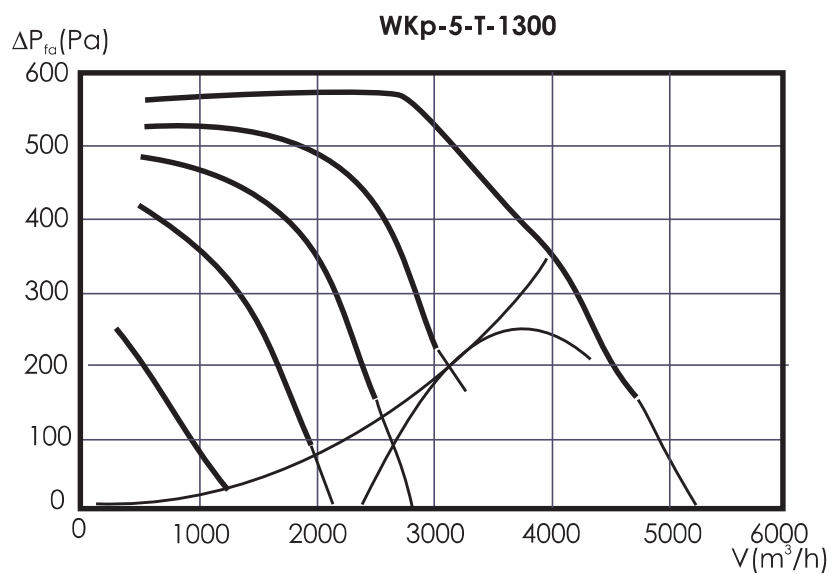

## Motor

3~400 V  
0,9 kW  
1,8 A  
750 rpm

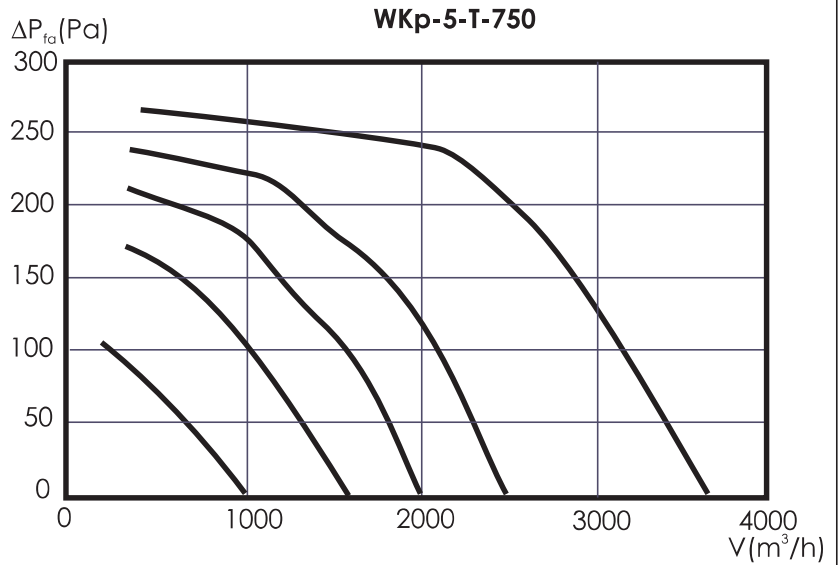

## Motor

3~400 V  
3,7 kW  
6,0 A  
1320 rpm

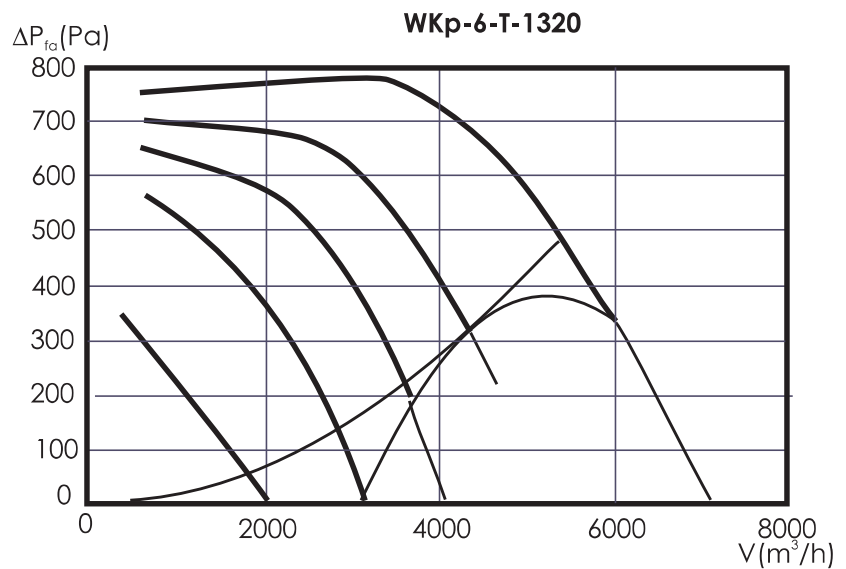

## Motor

3~400 V  
1,1 kW  
2,0 A  
790 rpm

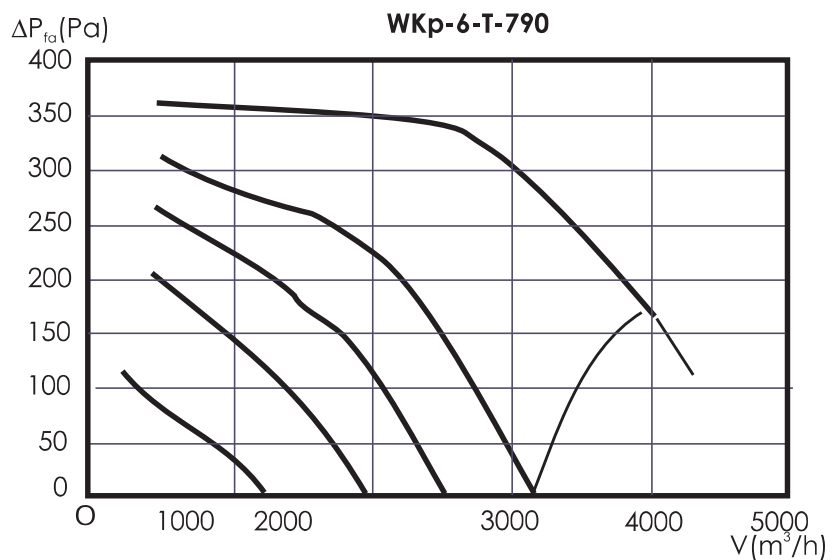

## Motor

3~400 V  
5,1 kW  
8,1 A  
1330 rpm

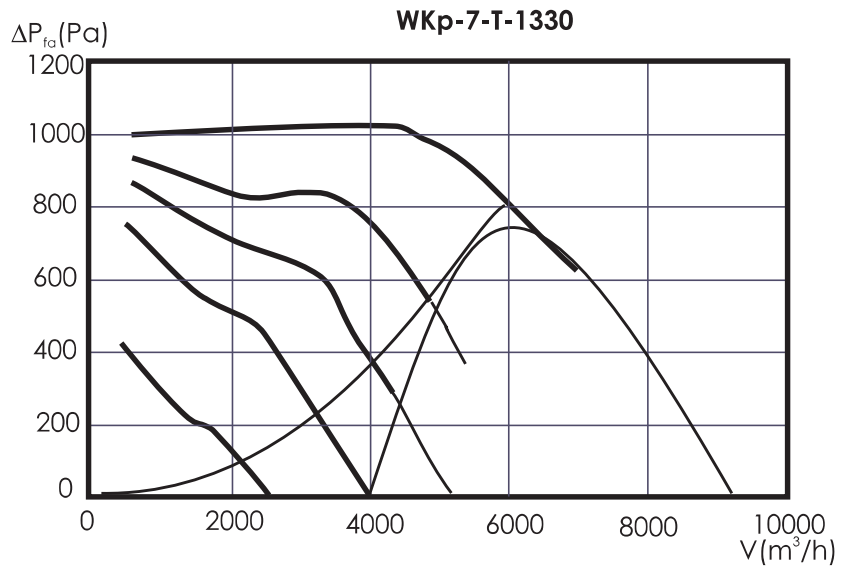

## Motor

3~400 V  
2,7 kW  
4,9 A  
830 rpm

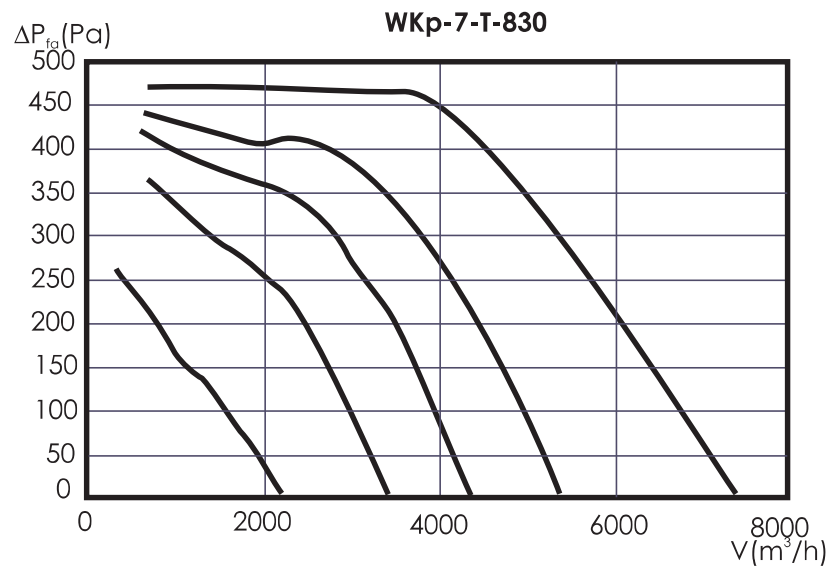

## Motor

3~400 V  
1,85 kW  
3,8 A  
600 rpm

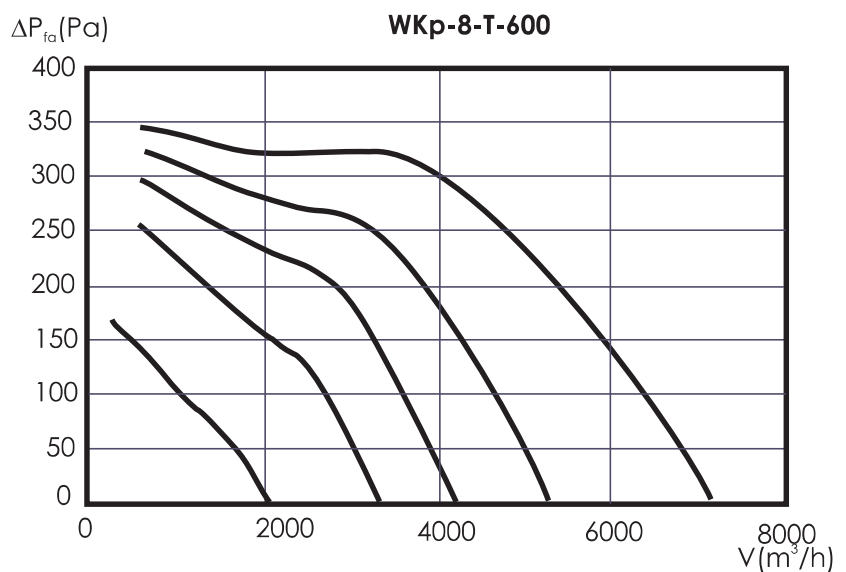

## DUCTED DAMPER TK

### USE AND CONSTRUCTION

TK dampers are used for absorbing sound in ducted installations, cooperating with WKp fans. They may also be used in other installations connected with P-20 profile.

The dampers are made of galvanized steel sheet with the collar with P-20 profile ensuring integration with particular parts of the installation in the same size.

Damping slotted lever is provided with an insert made of mineral wool with a veil 100 mm thick and  $\rho = 90 \text{ kg/m}^3$  dense.

The standard length of the damper is 1,0m. in order to decrease noise level the dampers should be fixed in a row (one after the other), however spacing in the form of channel interval should be preserved.

### INSTALLATION

The damper should be installed directly at the sound source. Flexible connectors must be insulated from outside.

The damper should be installed in accordance with denotations on the housing. The inlet side is provided with shields on the inserts decreasing pressure drop.

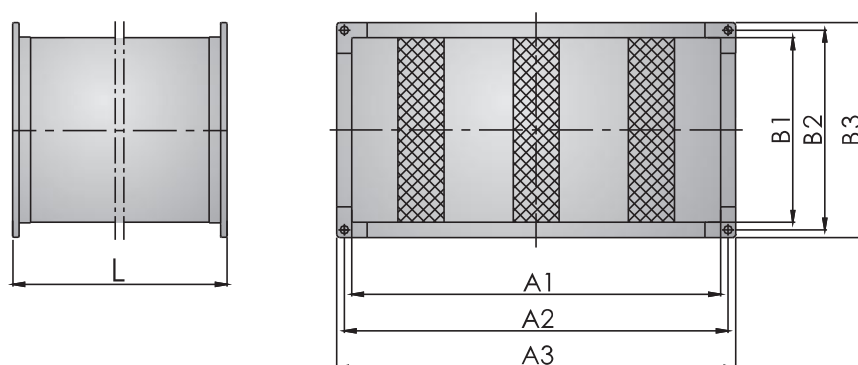

Damper size	A1 [mm]	A2 [mm]	A3 [mm]	B1 [mm]	B2 [mm]	B3 [mm]	L [mm]	Weight [kg]
TK-1	400	416	434	200	216	234	1000	13,6
TK-2	500	515	534	250	266	284	1000	18
TK-3	500	516	534	300	316	334	1000	23
TK-4	600	616	634	300	316	334	1000	26
TK-5	600	616	634	350	366	384	1000	28
TK-6	700	716	734	400	416	434	1000	32
TK-7	800	816	834	500	516	534	1000	40
TK-8	900	916	934	500	516	534	1000	45

Pressure drop on a damper

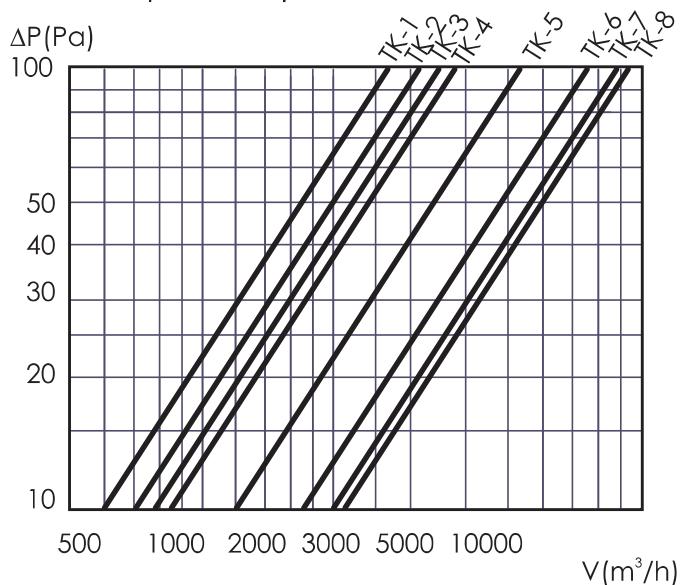

Dumping efficiency in dB

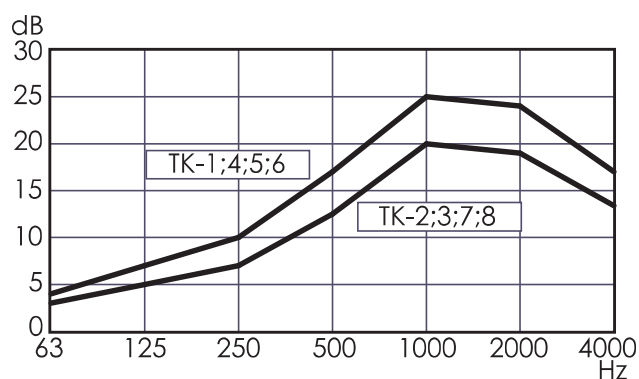



## DUCTED FILTER FK

### USE AND CONSTRUCTION

Filter in galvanized sheet housing, provided with collars for mounting in ducted installation. It is used in ventilation installations as the initial grade of dust extraction.

The filtering cassette in the form of pocket-like filter type FW-3 per PN EN 779 consists of a frame 25mm thick made of galvanized steel sheet. The pocket is made of synthetic needled cloth suspended on the frame.

### INSTALLATION

The filter may be installed in any position but pocket planes should always be positioned vertically.

There should also be ensured an appropriate spacing, specified by C dimension, allowing for filter cassette replacement.

### CLEANING

There is a covered inspection hole used for filter installation positioned at the bottom of the filter. Filter cassette should be replaced when the value of 250 Pa is exceeded. The filter cassettes may be regenerated.

### REMARK

The Cn speed in the chart indicates the speed of air inflow on the filter.

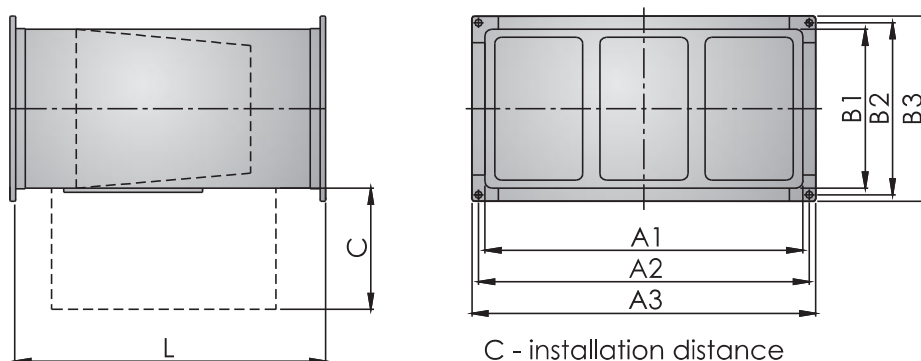

Damper size	A1 [mm]	A2 [mm]	A3 [mm]	B1 [mm]	B2 [mm]	B3 [mm]	C [mm]	L [mm]	Weight [kg]
FK-1	400	416	434	200	216	234	250	500	8
FK-2	500	515	534	250	266	284	300	500	9
FK-3	500	516	534	300	316	334	350	500	10
FK-4	600	616	634	300	316	334	350	500	11
FK-5	600	616	634	350	366	384	400	500	12
FK-6	700	716	734	400	416	434	450	500	13
FK-7	800	816	834	500	516	534	550	500	17
FK-8	900	916	934	500	516	534	550	500	19

Pressure drop

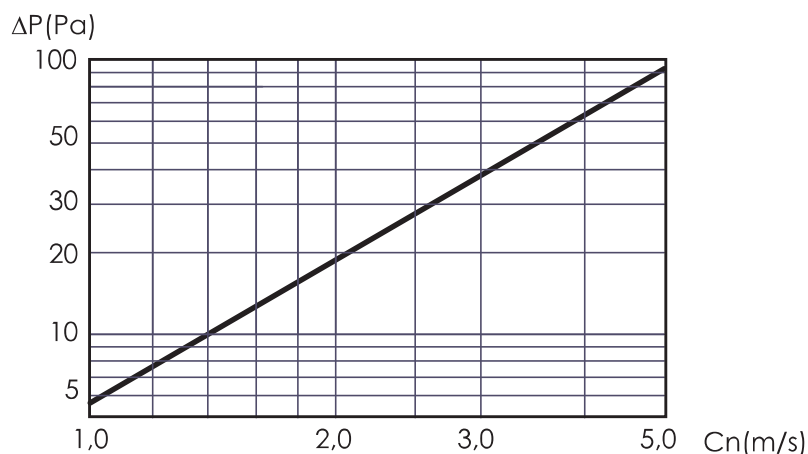

## ELECTRIC HEATER NEK

### CONSTRUCTION

The electric heater is provided with electric heaters with ribbed bars which operate at low temperature. The heaters are encased in galvanized sheet housing and are connected in heating sections.

### INSTALLATION

It is recommended to install the heater downstream the fan. In case of necessity of installing the heater upstream the fan, air temperature should not exceed 40°C.

### REMARK

The heaters should not operate at air speed lower than 2,5 m/s. Pressure drop is given for inflow speed.

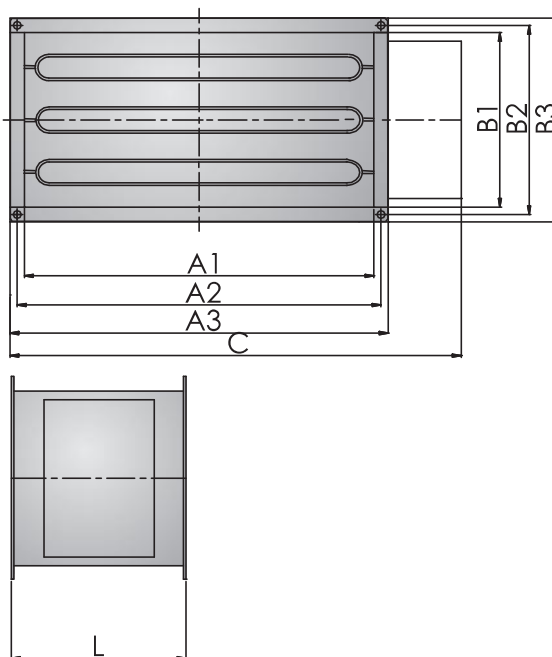

Heater size	A1 [mm]	A2 [mm]	A3 [mm]	B1 [mm]	B2 [mm]	B3 [mm]	C [mm]	L [mm]	Weight [kg]
NEK-1	400	416	434	200	216	234	500	500	8
NEK-2	500	515	534	250	266	284	550	500	11
NEK-3	500	516	534	300	316	334	550	500	12
NEK-4	600	616	634	300	316	334	650	500	19
NEK-5	600	616	634	350	366	384	650	500	21
NEK-6	700	716	734	400	416	434	750	500	27
NEK-7	800	816	834	500	516	534	850	500	30
NEK-8	900	916	934	500	516	534	950	500	33

### TECHNICAL DATA

Heater size	Min. air flow [m³/h]	Heating power [kW]	Voltage [V]	Connections	Number of rows
NEK-1	720	9	400	3+3+3	2
NEK-2	1100	12	400	6+3+3	3
NEK-3	1300	15	400	6+6+3	3
NEK-4	1600	27	400	9+9+9	4
NEK-5	1890	27	400	9+9+9	3
NEK-6	2500	30	400	12+9+9	3
NEK-7	3600	30	400	12+9+9	3
NEK-8	4000	30	400	12+9+9	3

Pressure drop

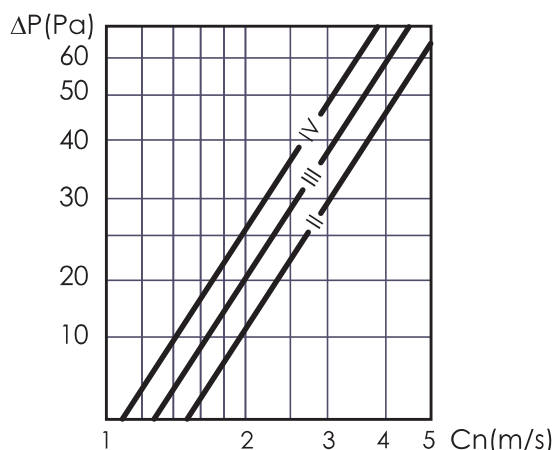

## WATER HEATER NWK

### USE AND CONSTRUCTION

Ducted water heater is used for ducted installations. The heater's housing is made of galvanized sheets with collars. The heat exchanger appears in the form of heating unit made of copper pipes provided with aluminium fuses. Heating water parameters: 90/70°C or 80/60°C. Connectors for water installation with inner thread.

### INSTALLATION

It is recommended to install the heaters downstream the fan according to the air flow direction. In case of upstream-the-fan installation, the air temperature should not exceed 40°C.

### CLEANING

Taking into consideration protection of the exchanger fuses against contamination it is required to use ducted air filter.

### EQUIPMENT

It is recommended to use freezing sensor cooperating with the heater.

### HEATER SELECTION

The following charts and table should be used for selection of heater power and temperature parameters downstream the heater.

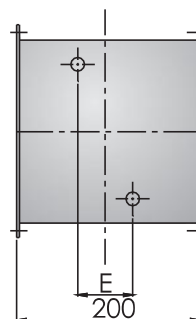
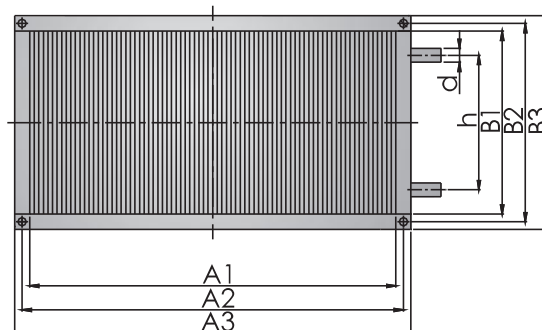

Heater size	A1 [mm]	A2 [mm]	A3 [mm]	B1 [mm]	B2 [mm]	B3 [mm]	E [mm]	d [mm]	Weight [kg]
NWK-1	400	416	434	200	216	234	-	22	6,5
NWK-2	500	515	534	250	266	284	-	22	9
NWK-3	500	516	534	300	316	334	50	22	10
NWK-4	600	616	634	300	316	334	50	22	11
NWK-5	600	616	634	350	366	384	50	22	13
NWK-6	700	716	734	400	416	434	50	28	16
NWK-7	800	816	834	500	516	534	50	28	19
NWK-8	900	916	934	500	516	534	50	28	21

### TECHNICAL DATA

Heater size	Air					Water	
	Flow [m <sup>3</sup> /h]	Power <sup>(1)</sup> [kW]	Power <sup>(2)</sup> [kW]	Δt <sup>(1)</sup> [°C]	Δt <sup>(2)</sup> [°C]	Pressure drop [kPa]	Flow [m <sup>3</sup> /h]
NWK-1	1200	10,8	9,5	25	22	6,9	0,5
NWK-2	1800	16,3	14,0	25	23	1,6	0,7
NWK-3	2500	22,5	19,5	25	20	6,6	0,9
NWK-4	3200	29,0	23,0	25	20	3,8	1,2
NWK-5	3500	31,5	25,3	25	20	3,4	1,4
NWK-6	5000	43,4	38,0	24	21	5,3	1,9
NWK-7	6000	58,6	49,9	27	23	6,9	2,6
NWK-8	6500	63,5	54,1	25	23	8,8	2,8

The values given in the table refer to: intake air temperature  $t_{p1}=0^{\circ}\text{C}$ , feeding water temperature (1) =90/70°C, (2) =80/60°C.

Pressure drop

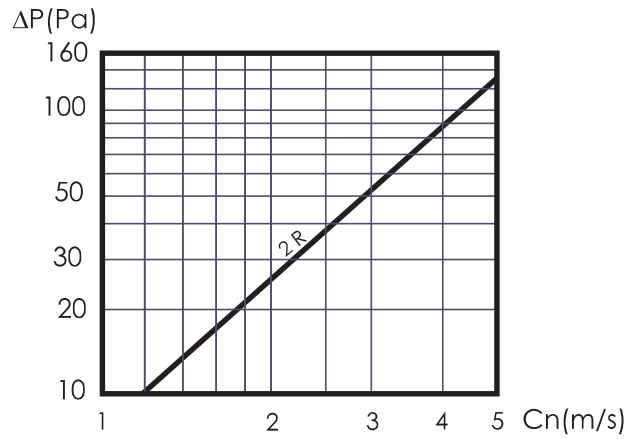

## FLEXIBLE CONNECTOR KE

Connector size	A1 [mm]	A2 [mm]	A3 [mm]	B1 [mm]	B2 [mm]	B3 [mm]	Weight [kg]
KE-1	400	416	434	200	216	234	2,0
KE-2	500	515	534	250	266	284	2,5
KE-3	500	516	534	300	316	334	3,0
KE-4	600	616	634	300	316	334	3,5
KE-5	600	616	634	350	366	384	3,7
KE-6	700	716	734	400	416	434	4,0
KE-7	800	816	834	500	516	534	4,5
KE-8	900	916	934	500	516	534	5,0

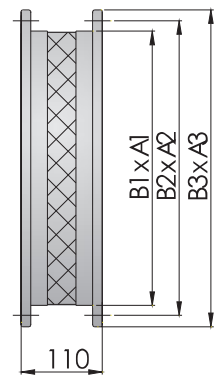

## DUCTED THROTTLE PK

Throttle size	A1 [mm]	A2 [mm]	A3 [mm]	B1 [mm]	B2 [mm]	B3 [mm]	Weight [kg]
KE-1	400	416	434	200	216	234	4,0
KE-2	500	515	534	250	266	284	5,5
KE-3	500	516	534	300	316	334	6,0
KE-4	600	616	634	300	316	334	6,5
KE-5	600	616	634	350	366	384	7,0
KE-6	700	716	734	400	416	434	8,5
KE-7	800	816	834	500	516	534	11,5
KE-8	900	916	934	500	516	534	12,0

